

## Stability Analysis of the Mathematical Model on the Control of HIV/AIDS Pandemic in a Heterogeneous Population

David Omale<sup>1</sup> and Remigius Okeke Aja<sup>2,\*</sup>

<sup>1</sup>Department of Mathematical Science, Kogi State University, Anyigba, Nigeria  
e-mail: davidubahi@gmail.com

<sup>2</sup>Department of Mathematics, College of Physical and Applied Sciences,  
Michael Okpara University of Agriculture, Umudike, Nigeria  
e-mail: ajah.remigius@mouau.edu.ng

\*Corresponding author

### Abstract

---

HIV/AIDS is a dreaded disease which has over the years claimed the life of so many people both female and male, adult and children in the whole continents or the globe. In this paper, a mathematical model on the control of HIV/AIDS was formulated using; vaccine, condom, therapeutic dose and public health campaign as control measures. The dynamic analysis of the model was carried out and the effective reproduction number  $R_0$  obtained. The local and global stability analyses were conducted. From the analysis carried out, we got that  $R_0 > 1$ , which shows that HIV/AIDS is endemic. Furthermore, the Maple software was applied to obtain the eigenvalues which validate the asymptotically stable nature of the disease equilibrium position. Matlab was used to simulate various submodels from the main model using numerical values of the parameters. Results obtained were discussed which extends some results in literature.

---

---

Received: June 6, 2019; Accepted: August 17, 2019

2010 Mathematics Subject Classification: 97Mxx, 92Bxx.

Keywords and phrases: HIV/AIDS, mathematical model, vaccine, condom, therapeutic dose, asymptotically stable, local and global stability, effective reproduction number.

Copyright © 2019 David Omale and Remigius Okeke Aja. This is an open access article distributed under the Creative Commons Attribution License, which permits unrestricted use, distribution, and reproduction in any medium, provided the original work is properly cited.

## Introduction

The human immunodeficiency virus since discovery has caused a lot of havoc to the global community by weakening the person's immune system as it destroys the most important cells that fight diseases and infection in human body. No effective cure exists right now against this disease, HIV, but with proper Medicare, HIV can be controlled. People are likely to get HIV more even because of many factors which includes; their sex partners, their risk behaviours, and where they live. HIV can be transmitted through sexual behaviours and needle or syringe use. Only certain body fluids – blood, semen (cum), pre seminal fluid (pre cum), rectal fluids, vaginal fluids and breast milk from a person who has HIV can transmit HIV virus [1]. These fluids must come in contact with the mucous membrane or damage tissue or be directly injected into the blood stream (from the needle or syringe) for transmission to occur. These mucous membranes are found inside the rectum vagina, penis or mouth.

The number of new HIV infection has declined globally by 21% since the estimated peak of the epidemic in 1997. 2.1 million people were newly infected with HIV worldwide in 2017 (NACA). In some part of the world, particularly within sub Sahara Africa, between 15% to 28% of the population are living with HIV. The study of HIV/AIDS control dynamics has been of great interest to both applied mathematicians and biologists due to its universal threat to human existence. Mathematical model have been used in the study of HIV/AIDS control and treatment.

[2] presented a deterministic mode, for controlling the spread of HIV/AIDS. [3] proposed a mathematical model for the dynamic of an infectious disease, a three dimensional model which assumed a non-linear incidence rate was quantitatively analysed to determine the stability of the equilibrium. [4] also proposed non-linear ordinary differential equation model to study the effect of vaccination on the spread of HIV/AIDS in a homogenously mixing population. [5] studied the impact of imperfect vaccine and their analysis showed that in a population of self interested individuals, there exists an overshooting of vaccine uptake level as the effectiveness of vaccination increases. The basic reproduction number of their model was calculated. [6] presented a mathematical model of HIV/AIDS at the Techiman municipality of Ghana and recommended that HIV/AIDS education should be intensified.

[7] presented a well structured mathematical model for the control of HIV/AIDS using condom, vaccine, therapeutic doses with public health campaign in a

heterogeneous population using ( $SVHEI_2A_2AA_T$ ) model formulation. The model is well posed and invariant within a well feasible deterministic region. Motivated by the work of [7] mention above, in this paper we considered the stability analysis of the model by looking at the local and global stability of the disease free equilibrium, and the basic reproduction number of the model. Some numerical simulations are also carried out and results discussed which extends some results in literature.

### Mathematical Model Formulation

The development of our model is based on the following assumptions, in [7] as,

1. The diseases HIV/AIDS is killing continuously.
2. Individual who contact this disease will definitely die of the disease if untreated or on control drug.
3. There is no medicine right now for total cure of this particular disease, therefore infected individual will live with the disease in his/her life time. Individual on HIV drug will remain on the drug forever.
4. Individual who is faithful to the drug will not die of HIV/AIDS.
5. There is no vaccine with 100% efficacy to prevent HIV/AIDS.
6. The available vaccines are imperfect; and so the vaccine will wane with time.
7. That not all the people within the sexually active population are willing to use condom whenever they have sex.
8. There are no vertical transmissions of the diseases.
9. That campaign reduces the rate of transmission; because those who are properly informed will reduce their exposure to infection whenever they meet any infectious opportunity.

We develop and analyze a mathematical model for HIV/AIDS transmission dynamics and control improving on the existing models as discoursed in our literature review. This is done by incorporating vaccination coverage, condom usage, campaign and therapeutic doses. The model is defined as a set of ordinary differential equations based on our assumptions about the dynamics of HIV/AIDS, and some biological interventions.

The interaction between the classes is described as follows: The susceptible is divided into three groups: ( $S$ ) represents the number of individuals not yet infected with the virus (HIV/AIDS) virus but are susceptible to the disease and its recruitment is not vaccinated, denoted by  $\pi$ , the other susceptible group is the vaccinated susceptible population denoted by ( $V$ ), when the susceptible population, as a result of public enlightenment campaign get vaccinated at the rate  $\delta_1$  and its recruitment is vaccinated at a proportion  $P$ , the vaccine has the ability to reduce the infection rate by a factor  $(1 - \theta_1)k$ , where  $\theta_1$  is the vaccine efficacy. When the efficacy is low, the infection may occur at the rate  $(1 - \theta_1)k$ ,  $\theta_1$  measure the efficacy of the vaccine such that  $0 \leq \theta_1 \leq 1$ . If  $\theta_1 = 1$ , vaccine is completely effective in preventing the population from infections, if the  $\theta_1$  is equal to 0 the vaccine is useless, as the whole population will be infected if they interact with infected population. The third susceptible class are those who use condom at the  $\delta_2$  and its recruitment is denoted by  $\omega$ , the failure rate in protecting an individual is denoted by  $\epsilon$ , in that case the condom users will be susceptible again. The effectiveness of the condom is denoted by  $\phi$ , such that,  $0 \leq \phi \leq 1$ . If  $\phi = 1$ , the condom is very effective and it can prevent the population from the infections, but if the condom efficacy is equal to zero (0), the condom is useless. The waning rate of the vaccine is denoted by  $\theta$  and the individual become susceptible again. Exposed class ( $E$ ) is made of individuals who have contracted the infection at the early stage, but are not capable of infecting others in the population yet, the exposed individual will become infectious at the rate  $\phi$  the public health campaign is denoted by  $c$ , the rate at which the infectious individual through effective public health campaign go for treatment is  $\tau$ , the non effectiveness of therapy is denoted by  $\sigma_1, \sigma_2$  such that  $1 \leq \sigma_1, \sigma_2 \leq 1$ , the infectious individual progress to full blown AIDS at the rate  $\eta$ , the delay rate in developing symptom is  $e$ , ( $A$ ) is the population of individual with clinical AIDS, it is a function of ( $I$ ), ( $I_2$ ) and ( $A_2$ ) developing disease symptoms. The susceptible may become infectious at the rate of infection  $k$ , the force of infection is given by

$$k = \frac{n_1\beta_1I_2 + n_2\beta_2A_2 + n_3\beta_3A_I}{N},$$

where

$n$  = number of sex partners,

$\beta_1$  = transmission rate from infectious individual not receiving treatment,

$\beta_2$  = transmission rate from infectious individual receiving treatment,

$\beta_3$  = transmission rate of AIDS individual who is undergoing therapy, (HAARTS).

In the force of infection,  $\beta_1 > \beta_2 > \beta_3$ . This shows that  $\beta_1$  contributes much on the transmission of the infection due to the fact that they are not receiving treatment, so they are not protected,  $\beta_2$  contributes much less on the transmission of the infection due to their HIV status, they have acquired HIV/AIDS but receiving treatment so their viral load will be significantly reduced, unless if they desist from taking their daily pills.  $\beta_3$  is expected to contribute least to the infection, since they just acquired the full virus and are aware of the AIDS status and they are receiving the daily therapy. There is natural death rate ( $\mu$ ) in the whole compartments, but there is an HIV/AIDS induced death rate in the (A) and ( $A_2$ ) classes. (A) and  $A_2$  are the same if proportion of (A) class stops receiving treatment, [7].

The total population at any time  $t$  is given by

$$N(t) = S(t) + V(t) + H(t) + E(t) + I(t) + I_2(t) + A_2(t) + A(t) + A_T(t).$$

The population is homogeneously mixed and each susceptible individual has equal chance of acquiring HIV infection when the individual come in contact with an infectious individuals.

Table 1 depicts the details of the variables and parameters used in the model.

**Table 1.** State variable of the HIV/AIDS with control strategies.

$S(t)$	Number of susceptible at time $t$ .
$V(t)$	Number of preventive vaccinated individual at time $t$ .
$H(t)$	Number of susceptible that are condom users at time $t$ .
$E(t)$	Latent/exposed individuals at time $t$ .
$I(t)$	Infectious individuals at time $t$ not receiving any treatment.
$I_2(t)$	Number of infectious individuals who are undergoing treatment.

$A(t)$	Number of individuals with full blown AIDS.
$A_T(t)$	Number or proportion of full blown AIDS who are undergoing therapy.
$A_2(t)$	Proportion of full blown AIDS who are not receiving the therapy.

**Table 2.** Parameter descriptions.

$\pi$	Population recruited into the susceptible class.
$P$	Proportion of susceptible recruited individual with lost preventive vaccination.
$\omega$	Proportion of susceptible recruited individual that uses condom.
$\mu$	Per capita death rate (Nature death).
$\alpha_i$	Disease induced death rate.
$\delta_1$	Preventive vaccination rate in the population.
$\delta_2$	Rate of condom usage in the population.
$\theta$	Waning rate of the vaccine.
$\varepsilon$	Improper condom usage.
$\varphi$	Condom efficacy or effectiveness.
$\theta_1$	Vaccination efficacy rate.
$\phi$	Progression rate of latent individual to infectious class.
$c$	Public health campaign rate.
$\sigma_1, \tau_C$	Rate of non effectiveness of the drug.
$\tau$	Treatment rate of infectious individual.
$\eta$	Rate of progression to full blown AIDS.
$e$	Reduction in developing symptom.
$r_1$	Rate at which those in the AIDS class receive treatment due to effectiveness of public health campaign.

---

$k$	Effective contact rate of the susceptible with the infectious classes and called force of infection.
$\delta_2$	The rate at which the susceptible individual uses condom effectively.
$r$	Rate at which unvaccinated and those who voluntarily refused to use condom become exposed to the infections.
$r_2$	Rate at which proportion of those in A class refused to receive the therapy and remain with AIDS.
$\alpha_2$	Disease induced death rate of those who refused therapy as AIDS individuals.

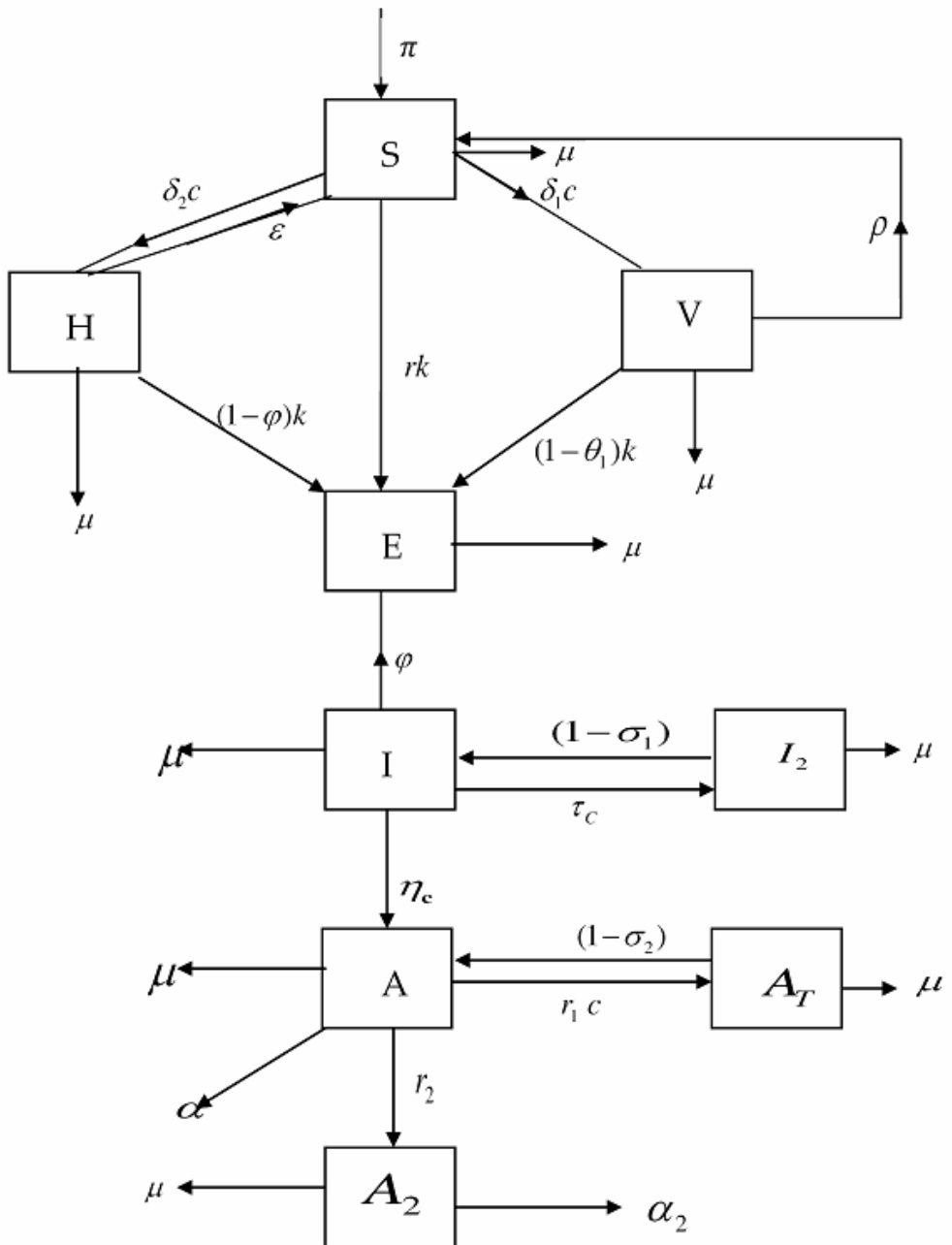

**Figure 1.** Model flow diagram illustrating the interactions of the different compartments.



From our assumptions and the flow chart we obtain the system of ordinary differential equations.

$$\begin{aligned}\frac{dS}{dt} &= \pi - \delta_1 cS - rkS - \delta_2 cS + \varepsilon H - \mu S + pV, \\ \frac{dV}{dt} &= \delta_1 cS - (1 - \theta_1)kV - pV - \mu V, \\ \frac{dH}{dt} &= -(1 - \varphi)kH - \varepsilon H + \delta_2 cS - \mu H, \\ \frac{dE}{dt} &= (1 - \varphi)kH + rkS + (1 - \theta_1)kV - \phi E - \mu E, \\ \frac{dI}{dt} &= \phi E + (1 - \sigma_1)I_2 - \tau cI - \eta cI - \mu I, \\ \frac{dI_2}{dt} &= \tau cI - (1 - \sigma_1)I_2 - \mu I_2, \\ \frac{dA_T}{dt} &= \eta cA - (1 - \sigma_2)A_T - \mu A_T, \\ \frac{dA}{dt} &= \eta cI + (1 - \sigma_2)A_T - \eta cA - \alpha A - \mu A - r_2 A, \\ \frac{dA_2}{dt} &= r_2 A - (\alpha_2 + \mu)A_2,\end{aligned}\tag{1}$$

where  $k$  is the effective contact rate given as

$$k = \frac{n_1 \beta_1 I_2 + n_2 \beta_2 A_2 + n_3 \beta_3 A_T}{N}.$$

Here follows the primary conditions

$$S(0) > 0, V(0) > 0, H(0) > 0, E(0) > 0, I(0) > 0,$$

$$I_2(0) > 0, A_2(0) > 0, A_T(0) > 0, A(0) > 0,$$

with the effective contact rate

$$\beta_1 > \beta_2 > \beta_3$$

but

$$N = S + V + H + E + I + I_2 + A + A_T + A_2.$$

## Analysis of the Model

### (1) Existence of equilibrium points

Let  $E(s^*, v^*, h^*, e^*, i^*, i_1^*, a^*, a_1^*, a_2^*)$  be the equilibrium point of normalized model system (1). The equilibrium points can be derived by setting the right hand side of normalized model system (1) equal to zero

$$\begin{aligned} \frac{ds^*}{dt} &= \pi + \delta_c + \varepsilon h^* - (n_1\beta_1 i + n_2\beta_2 i_2 + n_3\beta_3 a_2) s^* \\ &+ (\theta + \delta_2 c + p + \omega + \mu) s^* = 0, \end{aligned}$$

$$\begin{aligned} \frac{dv^*}{dt} &= (p + \theta) v^* - (1 - \theta_1)(n_1\beta_1 i + n_2\beta_2 i_2 + n_3\beta_3 a_2) v^* \\ &+ \delta_1 c s^* - \mu v^* = 0, \end{aligned}$$

$$\frac{dh^*}{dt} = (\omega + \delta_2 c) s^* - (1 - \varphi)(n_1\beta_1 i + n_2\beta_2 i_2 + n_3\beta_3 a_2) h^* - (\varepsilon + \mu) h^* = 0,$$

$$\begin{aligned} \frac{de^*}{dt} &= (1 - \varphi)(n_1\beta_1 i + n_2\beta_2 i_2 + n_3\beta_3 a_2) h^* + (1 - \theta_1)(n_1\beta_1 i + n_2\beta_2 i_2 + n_3\beta_3 a_2) v^* \\ &+ (n_1\beta_1 i + n_2\beta_2 i_2 + n_3\beta_3 a_2) s^* - (\phi + \mu) e^* = 0, \end{aligned}$$

$$\frac{di^*}{dt} = \phi e^* + (1 - \sigma_1) i_2 - (\tau c + \eta e + \mu) i^* = 0,$$

$$\frac{di_1}{dt} = \eta c a - ((1 - \sigma_2) + \mu) i_1 = 0,$$

$$\frac{da^*}{dt} = \eta e i^* + (1 - \sigma_2) a_1^* - (\eta c + \alpha + r_2 + \mu) a^* = 0,$$

$$\frac{da_2}{dt} = r_2 a - (\alpha + \mu) a_2 = 0,$$

$$\frac{da_1}{dt} = \tau ci - ((1 - \sigma_1) + \mu)a_1 = 0. \quad (2)$$

## (2) Existence of disease free equilibrium point (DFE)

The disease free equilibrium of the normalized model system is obtained as;

$$E_{01} = (S^*, h^*, v^*, e^*, i^*, i_2^*, a_2^*, a_1^*, a^*) = (S^*, h^*, v^*, 0, 0, 0, 0, 0, 0).$$

## (3) The effective reproduction number

The effective reproduction number  $R_0$  of the system is obtained by using the next generation operator method to assess the stabilities of the DFE and the endemic equilibrium (EE) point and the computation of the basic reproduction number is very essential. According to [8], the basic reproduction number is defined as the effective number of secondary infection caused by a typical infected individual during his/her entire period of infectiousness. So the meaning indicates the model's representation for the population with spread of infection. Therefore considering the largest (dominant) eigenvalue (Spectral radius) following results obtained;

$$\left[ \frac{\partial F_i(E_0)}{\partial X_j} \right] \left[ \frac{\partial V_i(E_0)}{\partial X_j} \right]^{-1},$$

where

$F_i$  indicates rate of appearance for new infection in the compartment  $i$ ,

$V_i^+$  indicates the transfer of individuals into compartment  $i$ ,

$V_i^-$  indicates the transfer of individuals out of compartment  $i$  with all different means,

$E_0$  considered as the disease free equilibrium.

If the DFE is locally asymptotically stable, then the disease cannot invade the population, that is  $R_0 < 1$ , and if on the other hand, the infected individual in the population grows, that means the disease can spread fast in the population, then  $R_0 > 1$ .

We therefore obtain the effective reproduction number by considering the state variables of those compartments that are capable of transmitting the disease; these compartments are the infected classes, i.e.,  $(e, i, i_2, a_2)$ .

The transmission model consists of the system of equations

$$F_i(x) = F_i(x) - V_i(x), \text{ where } V_i = V_i^-(x) - V_i^+(x).$$

The next step is to compute the matrix  $F$  and  $V$  which are  $M \times M$  matrix  $M$  where represents the infected classes stated above as

$$F = \frac{\partial F_i}{\partial x_j}(E_0) \text{ and } V = \left( \frac{\partial v_i}{\partial x_j}(E_0) \right),$$

where  $1 \leq i, j \leq m$  and  $F$  is non-negative and  $V$  is non-singular  $M$ -matrix (a matrix with inverse belonging to the class of positive matrix). Since  $F$  is non-negative and  $V$  is non-singular, then  $FV^{-1}$  is non-negative.

We then compute matrix  $FV^{-1}$  defined in [8] as the next generation matrix.

Therefore  $R_0 = \rho(FV^{-1})$ , where  $\rho(A)$  is the spectral radius of matrix  $A$  or the maximum modulus of the eigenvalues of  $A$ .

Using our model and applying the method explained above, we obtained the effective reproduction number as given below;

$$F = \begin{pmatrix} n_1 r \beta_1 s^* / N & n_2 r \beta_2 s^* / N & n_3 r \beta_3 s^* / N & n_4 r \beta_4 s^* / N \\ 0 & 0 & 0 & 0 \\ 0 & 0 & 0 & 0 \\ 0 & 0 & 0 & 0 \end{pmatrix}, \tag{3}$$

$$V = \begin{pmatrix} k_4 & 0 & 0 & 0 \\ -\phi & k_5 & -m_3 & 0 \\ 0 & -\tau_c & k_6 & 0 \\ 0 & 0 & 0 & k_9 \end{pmatrix}, \tag{4}$$

$$V^{-1} = \begin{pmatrix} \frac{1}{k_4} & 0 & 0 & 0 \\ \frac{\phi k_6}{k_4(k_6 k_5 - \tau_c m_3)} & \frac{k_6}{k_6 k_5 - \tau_c m_3} & \frac{m_3}{k_6 k_5 - \tau_c m_3} & 0 \\ \frac{\tau_c \phi}{k_4(k_6 k_5 - \tau_c m_3)} & \frac{\tau_c}{k_6 k_5 - \tau_c m_3} & \frac{k_5}{k_6 k_5 - \tau_c m_3} & 0 \\ 0 & 0 & 0 & \frac{1}{k_9} \end{pmatrix}, \tag{5}$$

where

$$\begin{aligned}
 k_4 &= \phi + \mu, \\
 k_5 &= \tau_c + \eta_c + \mu, \\
 k_6 &= (1 - \sigma_1) + \mu, \\
 m_3 &= 1 - \sigma_1 \\
 k_9 &= (\alpha + \mu).
 \end{aligned}$$

Evaluating  $(FV^{-1})$

$$\begin{pmatrix} n_1\beta_1r & n_2\beta_2r & n_3\beta_3r & n_4\beta_4r \\ 0 & 0 & 0 & 0 \\ 0 & 0 & 0 & 0 \\ 0 & 0 & 0 & 0 \end{pmatrix} \begin{pmatrix} \frac{1}{k_4} & 0 & 0 & 0 \\ \frac{\phi k_6}{k_4(k_6k_5 - \tau_c m_3)} & \frac{k_6}{k_6k_5 - \tau_c m_3} & \frac{m_3}{k_6k_5 - \tau_c m_3} & 0 \\ \frac{\tau_c \phi}{k_4(k_6k_5 - \tau_c m_3)} & \frac{\tau_c}{k_6k_5 - \tau_c m_3} & \frac{k_5}{k_6k_5 - \tau_c m_3} & 0 \\ 0 & 0 & 0 & \frac{1}{k_9} \end{pmatrix}.$$

Thus we have

$$FV^{-1} = \begin{pmatrix} P & N & R & Q \\ 0 & 0 & 0 & 0 \\ 0 & 0 & 0 & 0 \\ 0 & 0 & 0 & 0 \end{pmatrix}, \tag{6}$$

where,

$$P = \frac{rn_1\beta_1S}{Nk_4} + \frac{rn_2\beta_2\phi k_6S}{Nk_4(k_6k_5 - \tau_c m_3)} + \frac{r\tau_c\phi n_3\beta_3S}{Nk_4(k_6k_5 - \tau_c m_3)}$$

$$N = \frac{rn_2\beta_2S^*k_6}{N(k_6k_5 - \tau_c m_3)} + \frac{rn_3\beta_3S^*\tau_c}{(k_6k_5 - \tau_c m_3)N}$$

$$R = \frac{rn_2\beta_2S^*m_3}{(k_6k_5 - \tau_c m_3)N} + \frac{n_3\beta_3S^*rk_5}{k_6k_5 - \tau_c m_3},$$

$$Q = \frac{rn_4\beta_4S^*}{k_9}.$$

The Eigenvalues of  $FV^{-1}$  is

$$G = \begin{pmatrix} 0 \\ 0 \\ 0 \\ G \end{pmatrix}. \quad (7)$$

where  $G$  is given as;

$$G = \frac{r_1\beta_1 S^* Nk_4(k_6k_5 - \tau c m_3) + r_2\beta_2 S^* \phi k_6 Nk_4 + r_3\beta_3 S^* \tau c \phi Nk_4}{Nk_4^2(k_6k_5 - \tau c m_3)}. \quad (8)$$

Substituting the values of the variables in equation (8) above, then we have

$$G = \frac{r_1\beta_1(\phi + \mu)[((1 - \sigma_1) + \mu)(\tau_c + \eta_c + \mu) - \tau_c(1 - \sigma_1)] + r_2\beta_2\tau_c\phi(1 - \sigma_1 + \mu)(\phi + \mu) + r_3\beta_3\tau_c\phi(\phi + \mu)}{(\phi + \mu)[(1 - \sigma_1 + \mu)(\tau_c + \eta_c + \mu) - \tau_c(1 - \sigma_1)]}. \quad (9)$$

The basic reproduction number, represented with the big equation of normalized model system (1) with vaccination strategies, condom usage, public health campaign and treatment, is given as in (9) above.

$$G = R_0$$

$R_0$  measures the average number of new infections resulted by introducing one infected individual into the population of which are completely susceptible [9].

#### (4) Local stability of disease free equilibrium point

Local stability of disease free equilibrium  $E_0$  is obtained by the variational matrix  $M_0$  of the normalized model system corresponding to  $E_0$  as given below.

We set the systems by considering the normalized systems.

$$H_0 = \frac{ds}{dt}, P_0 = \frac{dv}{dt}, K_0 = \frac{dh}{dt}, G = \frac{de}{dt}, X = \frac{di}{dt},$$

$$Y = \frac{di_2}{dt}, Z = \frac{da_i}{dt}, M = \frac{da}{dt}, N = \frac{da_2}{dt}. \quad (10)$$

We therefore obtained our variational matrix of the normalized system

$$M_0 = \begin{pmatrix} -k_1 & \delta_c & \varepsilon & 0 & -m_5 & -m_6 & 0 & 0 & -m_7 \\ b_A & -k_2 & 0 & 0 & -m_5 & -m_6 & 0 & 0 & -m_7 \\ b_C & 0 & -k_3 & 0 & -m_5 & -m_6 & 0 & 0 & -m_7 \\ -r & -m_1 & -m_2 & -k_4 & -m_5 & -m_6 & 0 & 0 & -m_7 \\ 0 & 0 & 0 & \phi & -k_5 & -m_5 & 0 & 0 & 0 \\ 0 & 0 & 0 & 0 & \tau_c & -k_6 & 0 & 0 & 0 \\ 0 & 0 & 0 & 0 & \eta c_3 & 0 & -k_7 & m_4 & 0 \\ 0 & 0 & 0 & 0 & 0 & 0 & r_1 c & -k_8 & 0 \\ 0 & 0 & 0 & 0 & 0 & 0 & r_2 & 0 & -k_9 \end{pmatrix}. \tag{11}$$

We have the Jacobian matrix as  $J_{m_0} = |M_0 - \lambda I|$ .

The characteristic equation of  $M_0$  is obtained as.

$$\begin{aligned} f(\bar{\eta}) &= (\eta - (\theta + \delta_2 c + p + \omega + \mu))(\bar{\eta}_2 - (\delta_1 c + \mu))(\bar{\eta}_3 - (\varepsilon + \mu)) \\ &\quad (\bar{\eta}_4 - (\theta + \mu))(\bar{\eta}_5 - (\tau_c + \eta c_3) + \mu)(\bar{\eta}_6 - (1 - \sigma_1) + \mu) \\ &\quad (\bar{\eta}_7 - (\eta c + \alpha + r_2 \mu))(\bar{\eta}_8 - (1 - \sigma_2) + \mu)(\bar{\eta}_9 - (\alpha + \mu)) = 0, \end{aligned} \tag{12}$$

where  $\bar{\eta}_i$  are the eigenvalues

$$\begin{aligned} \bar{\eta}_1 &= (\theta + \delta_1 c + p + \omega + \mu), \bar{\eta}_2 = (\delta + \mu), \bar{\eta}_3 = (\varepsilon + \mu), \bar{\eta}_4 = (\theta + \mu), \\ \bar{\eta}_5 &= (\tau_c + \eta c_3 + \mu), \bar{\eta}_6 = ((1 - \sigma_1) + \mu), \bar{\eta}_7 = ((1 - \sigma_2) + \mu), \bar{\eta}_8 = (\alpha + \mu). \end{aligned} \tag{13}$$

This follows that, since none of the eigenvalues of the characteristic equation have negative real parts, the disease free equilibrium  $E_0$  is not locally asymptotically stable in the region  $\Omega$ .

**(5) Endemic equilibrium**

From the equilibrium of the normalized system, we equate the right hand to zero and with the basic reproduction number  $R_0$ , where

$$R_0 = \frac{rn_1\beta_1(\phi + \mu)[((1 - \sigma_1) + \mu)(\tau_c + \eta_c + \mu) - \tau_c(1 - \sigma_1)] + rn_2\beta_2\tau_c\phi(1 - \sigma_1 + \mu)(\phi + \mu) + rn_3\beta_3\tau_c\phi(\phi + \mu)}{(\phi + \mu)[(1 - \sigma_1 + \mu)(\tau_c + \eta_c + \mu) - \tau_c(1 - \sigma_1)]}. \tag{14}$$

We can obtain the endemic equilibrium of the normalized system of (1)

$$E^* = (s^*, h^*, v^*, e^*, i^*, i_2^*, a^*, a_1^*, a_2^*) \text{ exists if } R_0 > 1,$$

and  $(s^*, h^*, v^*, e^*, i^*, i_2^*, a^*, a_1^*, a_2^*)$  satisfies the following relations.

$$i_2^* = \frac{1}{((1 - \sigma_1) + \mu)} i^*, \quad (15)$$

$$a_1^* = \frac{\eta c \eta c_3 i^*}{((1 - \sigma_2) + \mu)(\eta c + \alpha + r_2 + \mu) - \eta c(1 - \sigma_2)}, \quad (16)$$

$$a^* = \frac{((\eta c_3((1 - \sigma_2) + \mu)(\eta c + \alpha + r_2) + \mu) - \eta c(1 - \sigma_2) + (1 - \sigma_2)\eta c \eta c_3) i^*}{(\eta c + \alpha + r_2 + \mu)((1 - \sigma_2) + \mu)(\eta c + \alpha + r_2 + \mu) - \eta c(1 - \sigma_2)}, \quad (17)$$

$$a_2^* = \frac{r_2(\eta c_3((1 - \sigma_2) + \mu)(\eta c + \alpha + r_2 + \mu) - \eta c(1 - \sigma_2) + (1 - \sigma_2)\eta c \eta c_3) i^*}{(\alpha + \mu)(\eta c + \alpha + r_2 + \mu)(1 - r_2 + \mu)(\eta c + \alpha + r_2 + \mu) - \eta c(1 - \sigma_2)}. \quad (18)$$

$$h^* = \frac{(\omega + \delta_2 c)(p + \theta)\delta_c\{(\eta c_3 - \tau_c + \mu)\} - \{(\delta_1 c + \mu)(\tau_c + \eta c_3 + \mu)\}k_2 i^*}{(\delta_1 c + \mu)k_2^2 - ((\omega + \delta_2 c)\varepsilon)^2 \delta_c(p + \theta)}. \quad (19)$$

$$V^* = -\frac{((p + \theta)\varepsilon(\tau_c + \eta c_3 + \mu) + (\tau_c + \eta c_3 + \mu))iB_1}{(p + \theta)\delta_c(\delta_1 c + \mu)(\theta + \delta_2 c + p + \omega + \mu)B_1 - (p + \theta)\varepsilon(\omega + \delta_2 c)\delta_c}, \quad (20)$$

$$S^* = \frac{((\delta_c(p + \theta)\varepsilon + B_1 + B_4 B_5)(\tau_c + \eta c_3 + \mu) + \varepsilon B_3)i}{(\theta + \delta_2 c + p + \omega + \mu)B_4 B_5}. \quad (21)$$

$$e^* = \frac{\{(1 - \mu)(\omega + \delta_2 c)(p + \theta)\delta_c\{(1 - \delta_1 c + \mu)k_2 + ((1 - \theta)(p + \theta)\varepsilon + 1)k_1 + r\delta_c(p + \theta)\varepsilon + B_1 + B_4 B_5\}(\tau_c + \eta c_3 + \mu) + \varepsilon b_3\}i}{(\delta_1 c + \mu)B_2^2 - ((\omega + \delta_2 c)\varepsilon)^2 \delta_c(p + \theta)(\theta + \mu)B_6 B_1 B_4 B_5}, \quad (22)$$

where

$$B_1 = (\theta + \delta_2 c + p + \omega + \mu)(\varepsilon + \mu)((\omega + \delta_2 c)\varepsilon),$$

$$B_2 = (\theta + \delta_2 c + p + \omega + \mu),$$

$$B_3 = (\omega + \delta_2 c)(p + \theta)\delta_c\{\eta c_3 - \tau_c + \mu\} - (\delta_1 c + \mu)(\tau_c + \eta c_3 + \mu)B_2 i,$$

$$B_4 = (p + \theta)\delta_c(\delta_1 c + \mu)B_1 B_2 - ((p + \theta)\varepsilon(\omega + \delta_2 c)\delta_c),$$



$$B_5 = (\delta_1 c + \mu) B_2^2 - ((\omega + \delta_2 c) \epsilon)^2 \delta_e (p + \theta),$$

$$B_6 = (\delta_1 c + \mu) \delta_c (p + \theta) \{ \theta + \delta_2 c + p + \omega + \mu \} B_1 - (p + \theta) \epsilon (\omega + \delta_2 c) \delta_c.$$

The unique endemic equilibrium  $E^*$  for normalized model exists and is locally asymptotically stable if  $R_0 > 1$  and unstable if  $R_0 < 1$ .

**Model Simulations**

In this section we simulate our various models from the main models and all the sub models to see the nature and numerical solution to them. We use Matlab 7.1 programming language for our simulation using the following parameter values as indicated in the following table.

**Table 3.** Parameter values

S/No.	Parameter	Description	Estimated value	Sources
1	$\pi$	Recruitment rate	10,000	[10]
2	$\rho$	Rate of preventive vaccination	0.01	[11]
3	$\omega$	Individuals that use condom	$0 \leq \omega \leq 1$	[12]
4	$\mu$	Natural death rate	$0.015 \leq \mu \leq 0.025$	[12]
5	$\alpha_1$	Disease induced death rate	$0.4 \leq \alpha_1 \leq 0.5$	[12]
6	$\delta_1$	Preventive vaccination rate in the population	0.45	[10]
7	$\delta_2$	Rate of condom usage in the population	$0 \leq \delta_2 \leq 1$	[12]
8	$\theta$	Warning rate of the vaccine	0.025	[10]
9	$\epsilon$	Rate at which condom are used wrongly	0.04	[10]
10	$\phi$	Condom efficiency rate	0.50	Estimated
11	$\theta_1$	Vaccine efficiency	$0 \leq \theta_1 \leq 1$	[11]

12	$\phi$	Progression rate of latent individual to infectious class	$0.06 \leq \phi \leq 0.45$	[13]
13	$c$	Public health campaign rate	$0 \leq c \leq 10$	[13]
14	$\sigma_1$	Rate at which people usually stop taking treatment (therapy)	$0.05 \leq \sigma_1 \leq 0.45$	Estimated
15	$\tau$	Treatment rate of infection individual	$0.06 \leq \tau \leq 0.2$	[13]
16	$\eta$	Rate of progression to full blown aids	0.1	[10]
17	$r_1$	Rate at which those in the AIDS class receive treatment due to effective campaign	$0.1 \leq r_1 \leq 0.4$	[13]
18	$\delta_2$	Rate of progress to AIDS of those who stop treatment	0.4	[10]
19	$K_i$	Force of infection	$0 \leq K_i \leq 1$	[13]
20	$e$	Reduction in developing symptom	0.19	[11]
21	$r_1$	Rate of exposure to infection of those who stop treatment	0.05	Estimated
22	$r_2$	Rate at which population of those in the AIDS class refused to receive the therapy	0.025	[14]
23	$\alpha_2$	Diseased induced death of those who refused therapy	$0.3 \leq \alpha_2 \leq 0.45$	[14]

Using the table above we simulate and generate the following graphs with the following initial conditions

$$S(0) = 10,000, H(0) = 3,000, V(0) = 2,500, E(0) = 1,500,$$

$$I(0) = 1000, I_2(0) = 600, A(0) = 500, A_1(0) = 400, A_2(0) = 200.$$

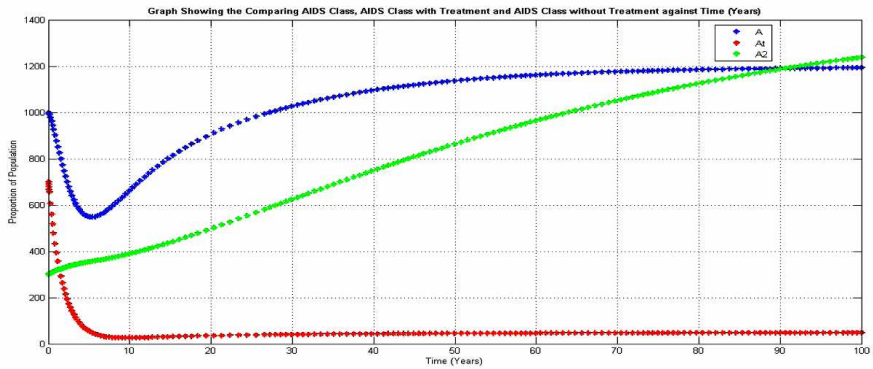

**Figure 2.** Comparison of aids class, aids class with treatment and without treatment.

This shows the interaction with various classes for more clear view. After a long period the AIDS with treatment rises above AIDS class without treatment indicating that the treatment has the power to prevent HIV/AIDS death.

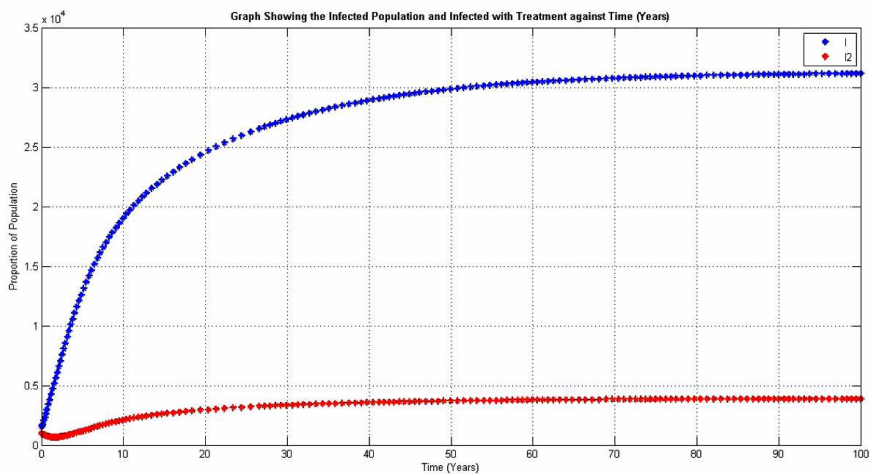

**Figure 3.** Comparison of infected class and infected class without treatment.

Figure 3 shows the comparison between infected class and infected class without treatment. The population of the infected class without treatment is always on increase due to the fact that those infected and are not taken any therapy consciously will be on the increase and eventually death but those infected may go for therapy and may not die of HIV/AIDS death, this may be the reason for a drop in the graph of the infected class below the infected class without treatment using the parameters value as described earlier on the initial condition.

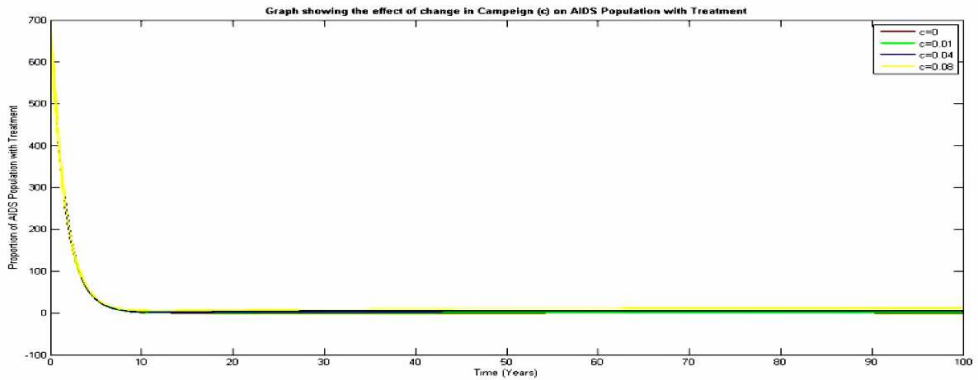

**Figure 4.** Effect of public health campaign on aids patient with treatment.

The use of HAART reduces the viral load of AIDS patient who is taking therapy regularly. Therefore use of public health campaign on the use of therapy will reduce the effect of HIV/AIDS death within the population as we vary values of  $c$  from  $c = 0.00$ ,  $c = 0.01$ ,  $c = 0.04$ ,  $c = 0.08$  the increase in the public health campaign will to reduction in patient with HIV/AIDS with treatment.

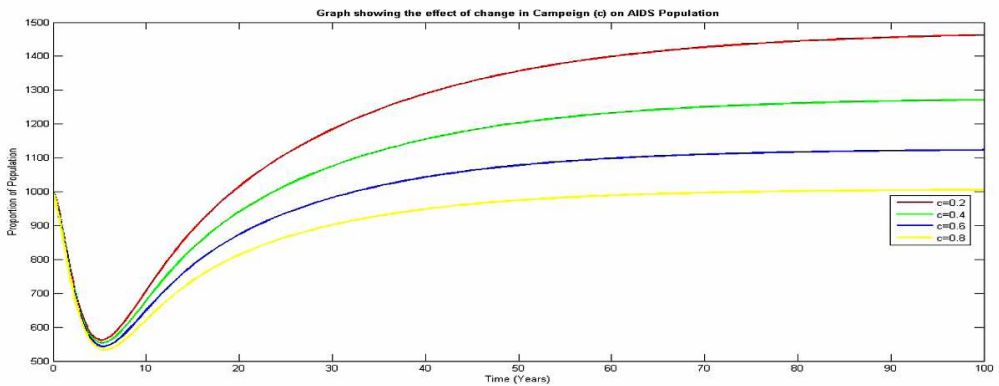

**Figure 5.** Effect of public health campaign on Aids population without treatment.

Figure 5 indicates that increase in public health campaign from  $c = 0.2$ ,  $c = 0.4$ ,  $c = 0.6$ ,  $c = 0.8$  will lead to a significant decline in the number of people who will adamantly refuse to present themselves for screening and eventually therapy as you can see above public health campaign will force people out of this class and attendant consequences.

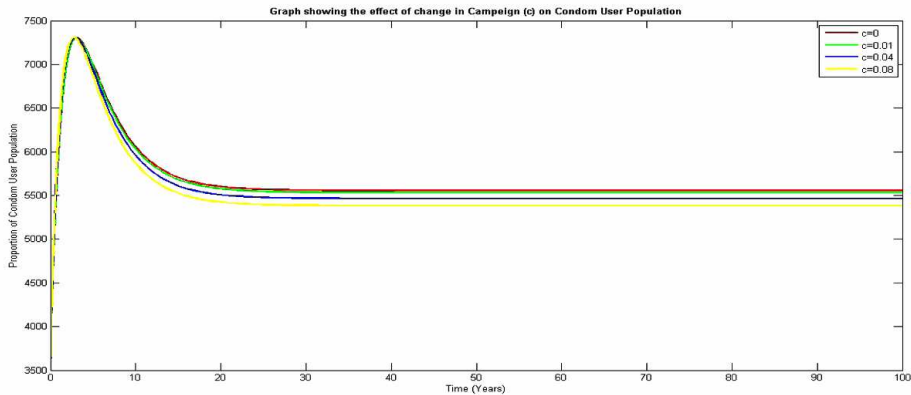

**Figure 6.** Effect of public health campaign on the use of condom.

Figure 6 shows the variation in public health campaign as  $c = 0.0, c = 0.1, c = 0.4, c = 0.8$  indicating that increasing the public health education in the population on the need for anyone who may indulge in legal or illicit sex to use condom will definitely reduce the number of people that will remain in this class for a long time after a period of 20 years using the parameter values

$$\begin{aligned} \pi &= 2000, \delta_2 = 0.5, c = 0.5, \varepsilon = 0.10, r = 0.25, k = 0.5, \rho = 0.01, \delta_1 = 0.45, \\ \mu &= 0.02, \varphi = 0.4, \theta_1 = 0.5, \phi = 0.743, \tau = 0.13, \eta = 0.1, \sigma_1 = 0.08, \sigma_2 = 0.4, \\ r_1 &= 0.05, r_2 = 0.025, \alpha_1 = 0.45, \alpha_2 = 0.375, e = 0.19. \end{aligned}$$

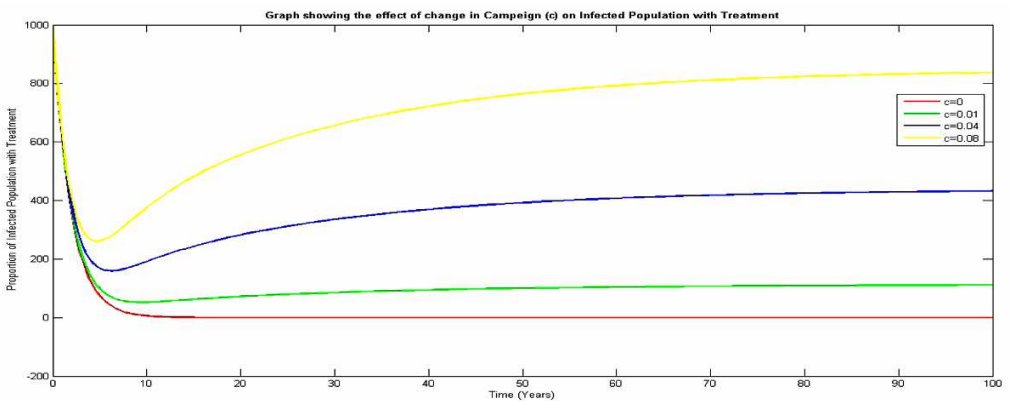
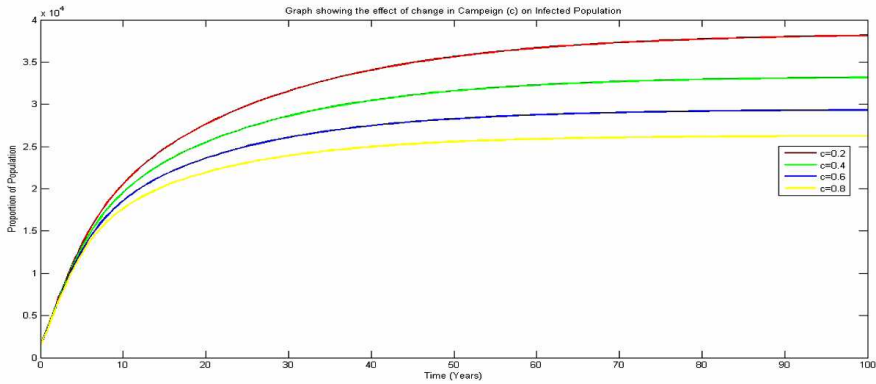

**Figure 7.** Variation on the change in public health campaign on infected population with treatment.

Using the parameter values

$$\begin{aligned} \pi &= 2000, \delta_2 = 0.5, c = 0.5, \varepsilon = 0.10, r = 0.25, k = 0.5, \rho = 0.01, \delta_1 = 0.45, \\ \mu &= 0.02, \varphi = 0.4, \theta_1 = 0.5, \phi = 0.743, \tau = 0.13, \eta = 0.1, \sigma_1 = 0.08, \sigma_2 = 0.4, \\ r_1 &= 0.05, r_2 = 0.025, \alpha_1 = 0.45, \alpha_2 = 0.375, e = 0.19. \end{aligned}$$

As seen above, if the public health campaign increases it will lead to significant increase in the number of those that will present themselves for therapy with the variation in public health education as  $c = 0.02$ .



**Figure 8.** Effect of campaign on infected population.

If we increase the public health campaign this will reduce the number of those to be infected, because with effective public health campaign ( $c$ ), people will not go for vaccine or for condom use.

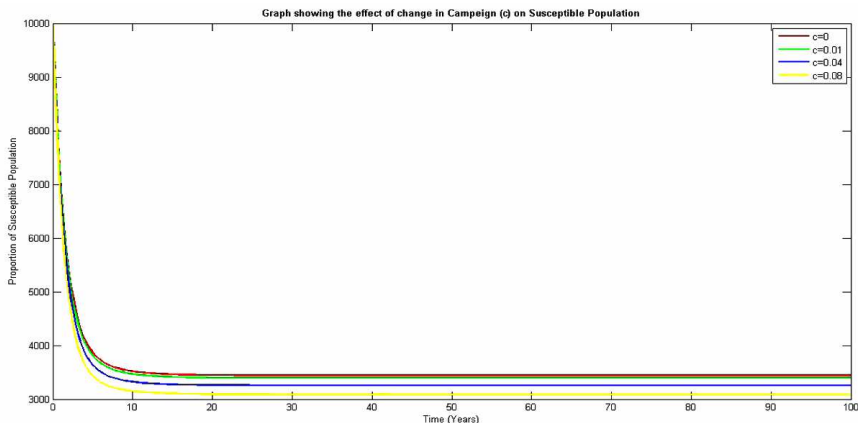

**Figure 9.** Effect of public health campaign on susceptible population.

In Figure 9 it shows that variation in public health campaign as indicated  $c = 0.00$ ,  $c = 0.01$ ,  $c = 0.04$ ,  $c = 0.08$  shows that increase in public health campaign on the need for the total population to embark on compulsory screening and vaccination will definitely reduce the total number of people who will definitely be susceptible to the virus since the majority of the population are well covered and protected with effective vaccination coverage rate. Keeping the other parameters constant.

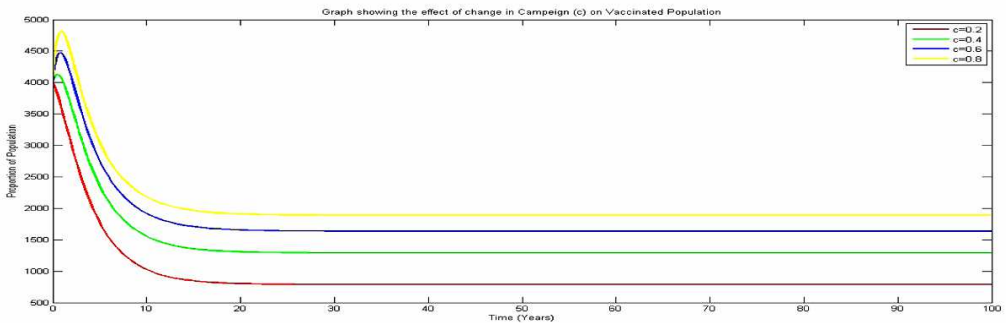
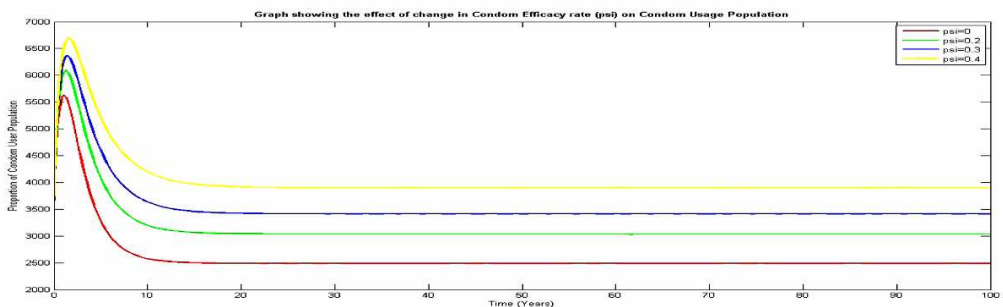

**Figure 10.** Effect of public health campaign on the vaccination class.

Keeping the values of the parameter

$$\begin{aligned} \pi &= 2000, \delta_2 = 0.5, c = 0.5, \varepsilon = 0.10, r = 0.25, k = 0.5, \rho = 0.01, \delta_1 = 0.45, \\ \mu &= 0.02, \varphi = 0.4, \theta_1 = 0.5, \phi = 0.743, \tau = 0.13, \eta = 0.1, \sigma_1 = 0.08, \sigma_2 = 0.4, \\ r_1 &= 0.05, r_2 = 0.025, \alpha_1 = 0.45, \alpha_2 = 0.375, e = 0.19 \end{aligned}$$

Increasing in the public health campaign from  $c = 0.00$ ,  $c = 0.01$ ,  $c = 0.04$ ,  $c = 0.08$  to  $c = 0.2$ ,  $c = 0.4$ ,  $c = 0.6$ ,  $c = 0.8$  will lead to increase in the number of those who will be ready to present themselves for vaccination after a long period of time.



**Figure 11.** Efficacy of condom in the population.

As seen in Figure 11 the increase in condom efficacy with  $\phi = 0.0$ ,  $\phi = 0.2$ ,  $\phi = 0.3$ ,  $\phi = 0.4$  will increase the number of people using condom that will be protected since highly efficacious condom prevent and cover the population from been infectious to the disease HIV/AIDS within the susceptible population.

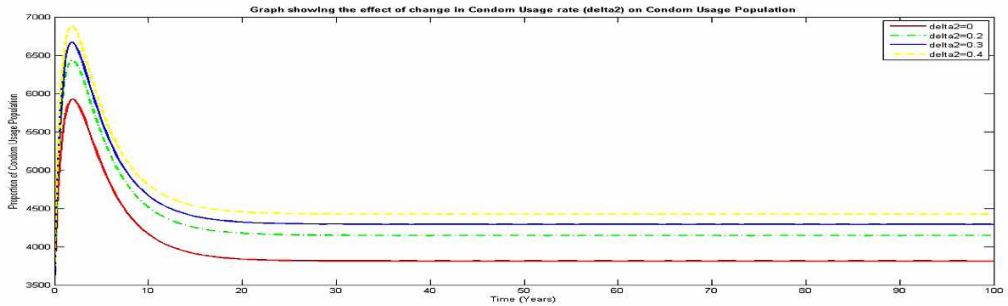

**Figure 12.** Variation of condom usage rate on condom users population.

As the number of people that are using condom increases these in turn increases the rate that the population will be protected from the dreaded HIV/AIDS disease. This leads to an optimal control of the disease within the population under consideration using different values of  $\delta_2 = 0.0$ ,  $\delta_2 = 0.2$ ,  $\delta_2 = 0.3$ ,  $\delta_2 = 0.4$  keeping other parameter values constant. The early rise is due to effective public health campaign and a little drop shows some level of stigma attached to the name condom but it is very much effective in reducing the spread of HIV/AIDS infection within a given population. Significantly, then those entering the susceptible class will reduce drastically which in turn will lead to elimination of HIV/AIDS from the population under investigation

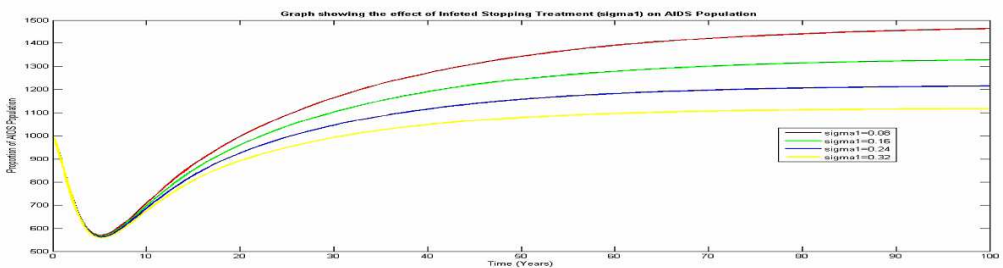

**Figure 13.** Effect of continuous therapy of the infected class.

In Figure 13 increase in the use of therapy will decrease the number of infected people that will die of the disease as shown  $\delta_1 = 0.08$ ,  $\delta_1 = 0.16$ ,  $\delta_1 = 0.24$ ,  $\delta_1 = 0.32$



keeping the other parameter

$$\begin{aligned} \pi &= 2000, \delta_2 = 0.5, c = 0.5, \varepsilon = 0.10, r = 0.25, k = 0.5, \rho = 0.01, \delta_1 = 0.45, \\ \mu &= 0.02, \varphi = 0.4, \theta_1 = 0.5, \phi = 0.743, \tau = 0.13, \eta = 0.1, \sigma_1 = 0.08, \sigma_2 = 0.4, \\ r_1 &= 0.05, r_2 = 0.025, \alpha_1 = 0.45, \alpha_2 = 0.375, e = 0.19. \end{aligned}$$

This means that increase in the rate of continuous therapeutic doze of those infected with HIV/AIDS over a long period of time reduces the number of HIV/AIDS death within the population.

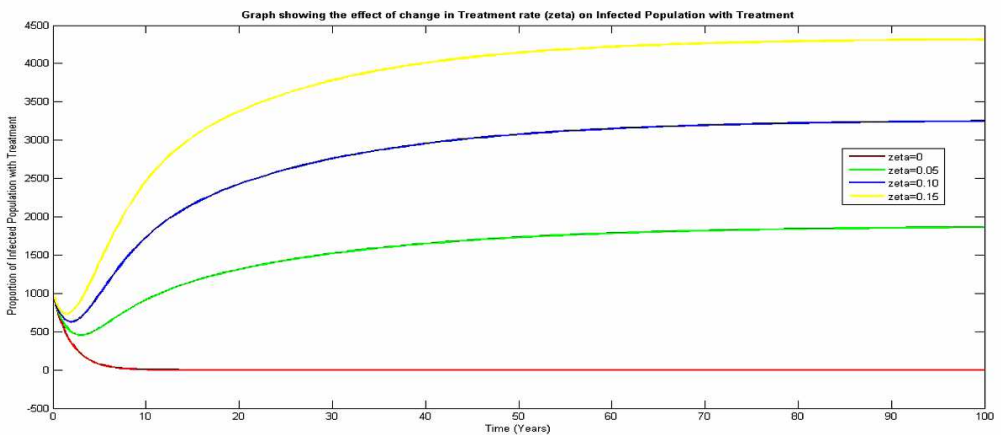
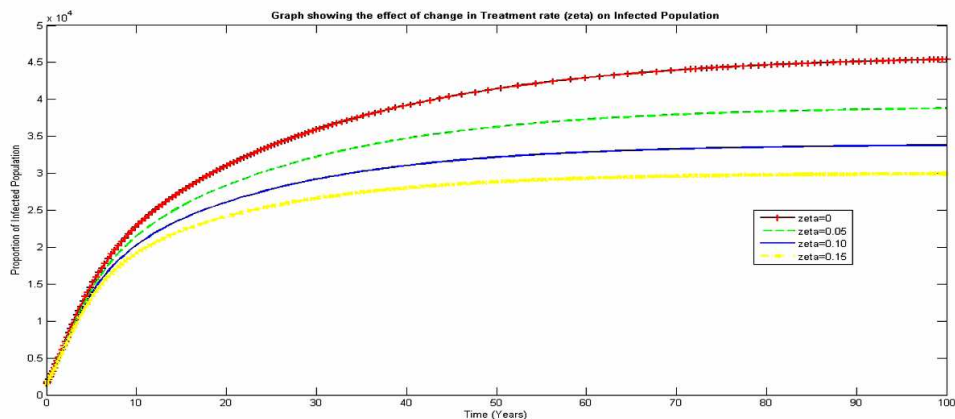

**Figure 14.** Variation in treatment on the infected population with treatment.

If the rate at which infected people comes up for treatment increases, it also increases the proportion of people who will remain in the infectious class and who will not die of HIV/AIDS and they will live their normal lives with the parameter

$$\begin{aligned} \pi &= 2000, \delta_2 = 0.5, c = 0.5, \varepsilon = 0.10, r = 0.25, k = 0.5, \rho = 0.01, \delta_1 = 0.45, \\ \mu &= 0.02, \varphi = 0.4, \theta_1 = 0.5, \phi = 0.743, \tau = 0.13, \eta = 0.1, \sigma_1 = 0.08, \sigma_2 = 0.4, \\ r_1 &= 0.05, r_2 = 0.025, \alpha_1 = 0.45, \alpha_2 = 0.375, e = 0.19 \end{aligned}$$

with the value of  $\eta$  varies accordingly  $\eta = 0.0, \eta = 0.06, \eta = 0.10, \eta = 0.15$ .



**Figure 15.** Change in rate of treatment rate on the infected population.

As seen in Figure 15 increase in the rate of treatment  $\eta$  on the infected population will lead to reduction in those in the infected class, the infected class will rise as a result of low awareness and when the awareness is maintain over a long period of time it reaches its equilibrium position at about 60 years and remain stable. This group will not die of HIV/AIDS disease.

## Conclusion

In this paper, HIV/AIDS epidemic model was considered in which a nonlinear incidence rate was introduced. The general dynamic of our model is determined by the study of the basic reproduction number  $R_0$ . Where the  $R_0 < 1$ , the disease free equilibrium is globally asymptotically stable and when the  $R_0 > 1$ , the unique endemic equilibrium is globally asymptotically stable.

We finally suggest that the appropriate use of condom both by the female and male will combat the spread of the disease, and sexual habits reduce both the prevalence and incidence of the HIV/AIDS pandemic.

Empower people infected and affected by HIV/AIDS through training, consulting and education to cope with the circumstances.

Develop standards and guidelines that can lead to the institutionalization of the best practices to mitigate the impact of AIDS.

Ensure that prevention programme are developed and targeted at vulnerable groups

such as women and children adolescent and young adult, sex workers, long distance commercial vehicle driver, prison inmate's migrant labour etc.

## Acknowledgement

We wish to acknowledge all the authors we consulted their work while reviewing literature. In a special way we wish to acknowledge Prof. G. C. E. Mbah (Head of Department, University of Nigeria, Nsukka) for his tireless efforts in tutoring us.

## References

- [1] CDC, HIV/AIDS updates on control and prevention, 2017.
- [2] Tunde T. Yusuf and Francis Benyah, Optimal strategy for controlling the spread of HIV/AIDS disease: a case study of South Africa, *J. Biol. Dyn.* 6(2) (2012), 475-494.  
<https://doi.org/10.1080/17513758.2011.628700>
- [3] A. B. Gumel, S. M. Moghadas and R. E. Mickens, Effect of a preventive vaccine on the dynamics of HIV transmission, *Commun. Nonlinear Sci. Numer. Simul.* 9(6) (2004), 649-659. [https://doi.org/10.1016/S1007-5704\(03\)00024-8](https://doi.org/10.1016/S1007-5704(03)00024-8)
- [4] Ram Naresh, S. Pandey and A. K. Misra, Analysis of a vaccination model for carrier dependent infection diseases with environmental effect, *Nonlinear Anal. Model. Control* 13(3) (2008), 331-350.
- [5] Bin Wu, Feng Fu and Long Wang, Imperfect vaccine aggravates the long-standing dilemman of voluntary vaccination, *PLoS ONE* 6(6) (2011), e20577.  
<https://doi.org/10.1371/journal.pone.0020577>
- [6] Isaac Kwasi Adu, Douglas Kwasi Boah and Stephen Eduafo, Mathematical model of HIV/AIDS at Techiman municipality, Ghana, *International Journal of Mathematics and Statistics Studies* 3 (2015), 1-10.
- [7] D. Omale, R. O. Aja and G. C. E. Mbah, Mathematical model on the control of HIV/AIDS pandemic using condom, vaccine therapeutic doses and public health campaign in heterogeneous population, *Transactions of the Nigerian Association of Mathematical Physics* 5 (2017), 297-308.
- [8] O. Diekmann, J. A. P. Heesterbeek and J. A. J. Metz, On the definition and the computation of the basic reproduction ratio  $R_0$  in models of infectious diseases in heterogeneous populations, *J. Math. Biol.* 28 (1990), 365-382.  
<https://doi.org/10.1007/BF00178324>

- 
- [9] R. M. Anderson, J. Swinton and G. P. Garnett, Potential impact of low efficacy HIV-1 vaccines in populations with high rate of infection, *Proc. Biol. Sci.* 261 (1995), 147-151.  
<https://doi.org/10.1098/rspb.1995.0129>
- [10] Oluwaseun Sharomi, Chandra N. Podder, Abba. B. Gumel and Baojun Song, Mathematical analysis of the transmission dynamics of HIV/TB coinfection in the presence of treatment, *Math. Biosci. Eng.* 5(1) (2008), 145-174.  
<https://doi.org/10.3934/mbe.2008.5.145>
- [11] J. P. Liu, E. Manheimer and M. Yang, Herbal medicines for treating HIV infection and AIDS, *Cochrane Database Syst. Rev.* 3 (2005), CD003937.  
<https://doi.org/10.1002/14651858.CD003937.pub2>
- [12] Hai-Feng Huo and Rui Chen, Stability of an HIV/AIDS treatment model with different stages, *Discrete Dyn. Nat. Soc.* 2015, Art. ID 630503, 9 pp.  
<http://dx.doi.org/10.1155/2015/630503>.
- [13] Cristiana J. Silva and Delfim F. M. Torres, A TB-HIV/AIDS coinfection model and optimal control treatment, *Discrete Contin. Dyn. Syst.* 35 (2015), 4639-4663.  
<https://doi.org/10.3934/dcds.2015.35.4639>
- [14] Ratera Safiel, Estomih S. Massawe and Daniel Oluwole Makinde, Modelling the effect of screening and treatment on transmission of HIV/AIDS infection in a population, *American Journal of Mathematical and Statistics* 2(4) (2012), 75-88.  
<https://doi.org/10.5923/j.ajms.20120204.03>